

36" Object Marker

12"X 6" Yellow Flexible High Intensity Reflective Sheeting. White Panel and Post. Overall height of unit is 36".

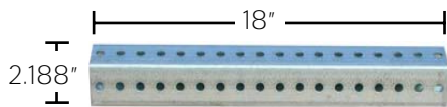

#105NS Driveable Base (P)

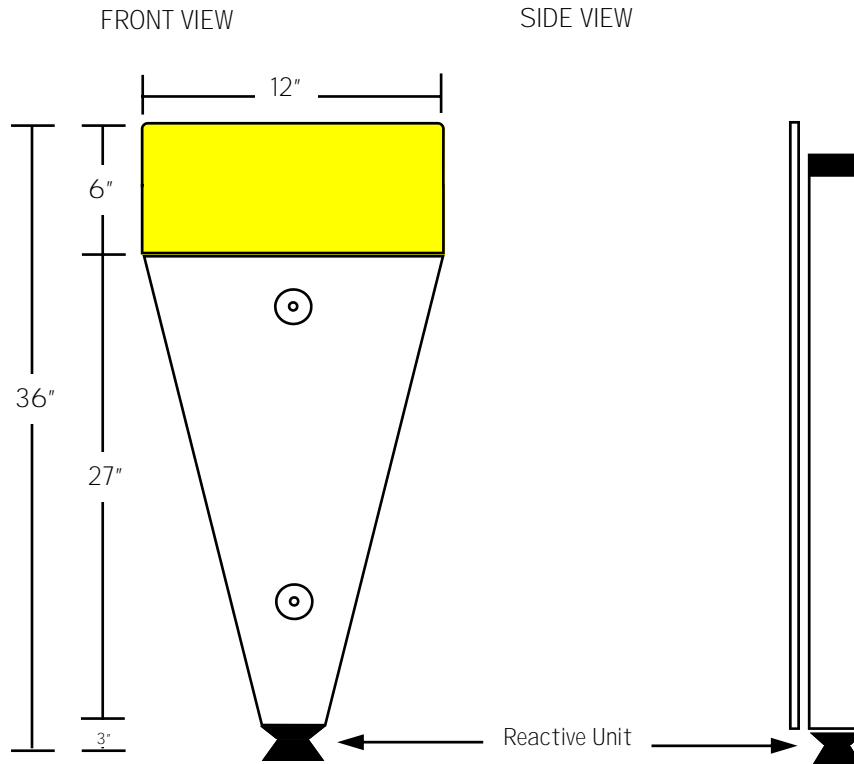
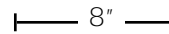

#101NS Fixed Base (F)

This product can be used with either the #105NS Driveable Base (P) or #101NS Fixed Base (F)

SPECIFICATIONS

- Post and panel is constructed of flexible polyethylene plastic that is resistant to: ultraviolet light, ozone, and hydrocarbons.
- Unit has a reactive spring assembly tested 145 lb tension with stainless steel cable.

RECOMMENDED USES

- Ideal for use in marking islands, gore areas, etc.

IMPACTrecovery
SYSTEMS

"Impacting Today's Roads for a Safer Tomorrow"

246 W. Josephine
San Antonio, TX 78212
(210) 736-4477 (210) 734-6448
Toll Free: (800) 736-5256
www.impactrecovery.com